

WAFER SWING CHECK VALVE



Size : DN 40 to 600
Ends : Between flanges ISO PN10/16
Min Temperature : - 10°C
Max Temperature : +80°C in NBR, 110°C in EPDM , 180°C in FKM
Max Pressure : 16 Bars up to DN200 (10 bars over)
Specifications : Wafer swing check valve
Vertical or horizontal position
Between flanges type

Materials : Carbon steel or Stainless steel

WAFER SWING CHECK VALVE

SPECIFICATIONS :

- Wafer swing check valve
- Vertical position with ascendant fluid or horizontal position (respect the flow direction indicated by the arrow)
- Between flanges ISO PN10/16
- With hoisting eye
- Short length
- Economical solution
- Monobloc disc and stem for a better mechanical strength
- Integrated body gasket

USE :

- Heating, water distribution and watering
- Min and max Temperature Ts : - 10°C to + 80°C for carbon steel NBR type **Ref.351**
- Min and max Temperature Ts : - 10°C to + 110°C for carbon steel EPDM type **Ref.364**
- Min and max Temperature Ts : - 10°C to + 180°C for stainless steel FKM type **Ref.365**
- Max Pressure Ps : 16 bars up to DN 200 included and 10 bars over
- **Do not use with pulsatory speed**
- **Max Speed : 3 M. / Sec.**

HEAD LOSS GRAPH :

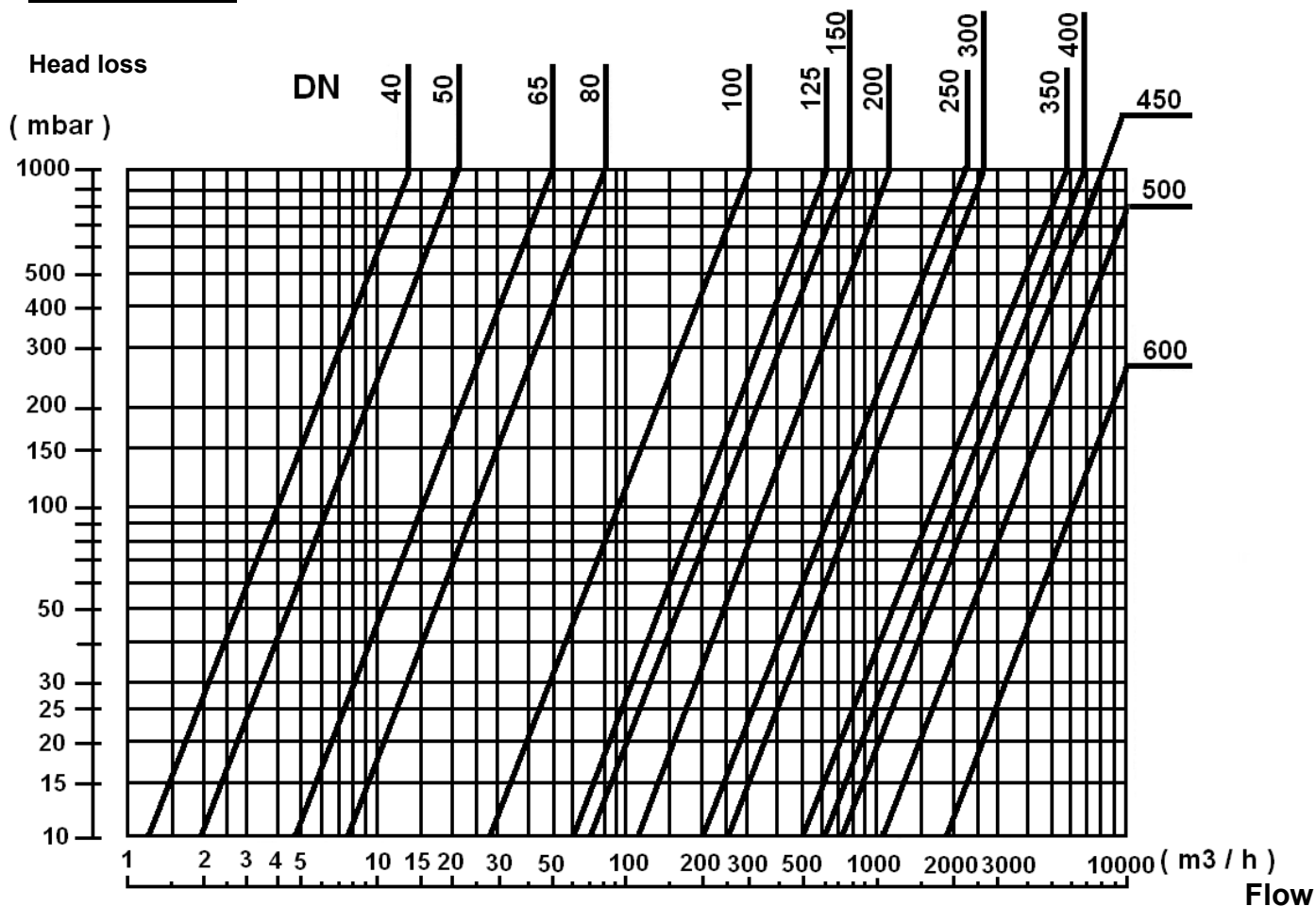

WAFER SWING CHECK VALVE

RANGE :

- Galvanized carbon steel body with NBR gasket between flanges ISO PN16 **Ref. 351** DN40 to DN 300
- Galvanized carbon steel body with EPDM gasket between flanges ISO PN16 **Ref. 364** DN40 to DN 600
- Stainless steel body with FKM gasket between flanges ISO PN16 **Ref. 365** DN40 to DN 600
- Stainless steel body with FKM gasket between flanges ISO PN10 **Ref. 365401 and 365451** DN400 to DN 450

MATERIALS :

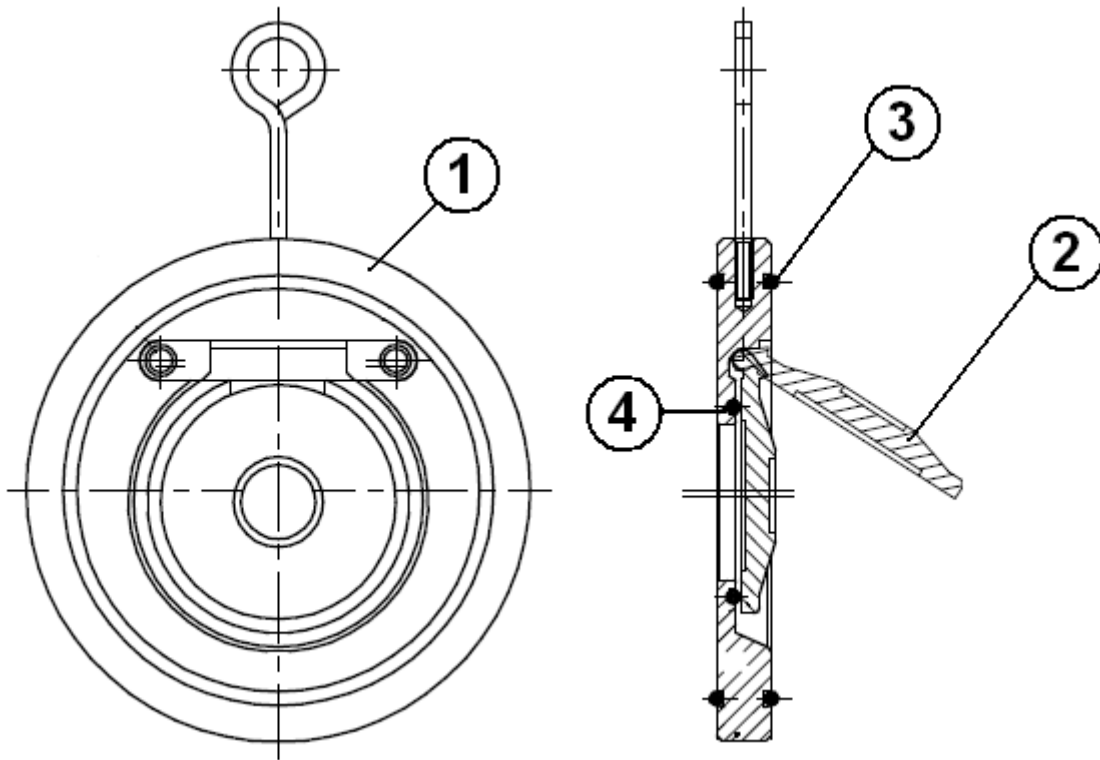

Item	Designation	Materials 351	Materials 364	Materials 365
1	Body	Carbon steel with chromium plated Q235	Carbon steel with chromium plated Q235	ASTM A351 CF8M
2	Disc	Carbon steel with chromium plated Q235	Carbon steel with chromium plated Q235	ASTM A351 CF8M
3	Seat	NBR	EPDM	FKM
4	Gasket	NBR	EPDM	FKM

WAFER SWING CHECK VALVE

SIZE BETWEEN ISO PN16 FLANGES TYPES (in mm) :

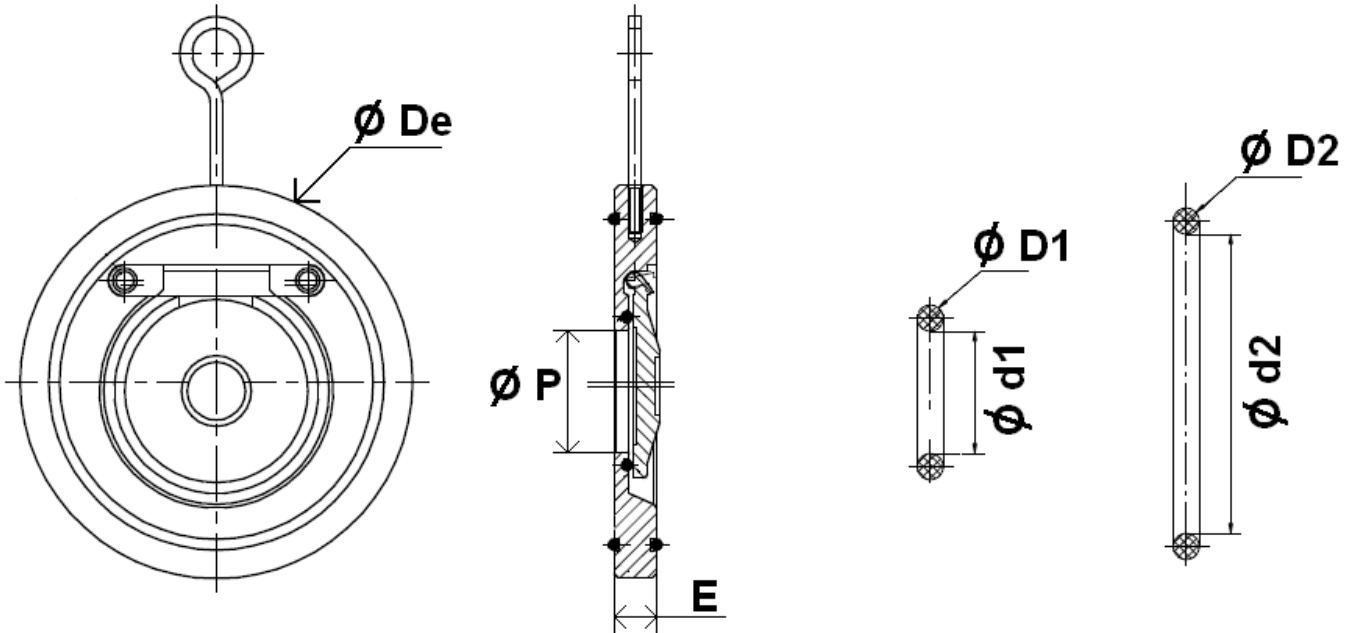

Ref.	DN	40	50	65	80	100	125	150	200	250	300	350	400	450	500	600
351 364 / 365	E	14	14	14	14	18	18	20	22	26	32	36	41	50	56	56
	$\varnothing De$	94	109	129	144	164	194	220	275	331	386	446	497	557	619	736
	$\varnothing P$	22	32	40	54	70	92	112	154	192	227	270	315	359	410	490
	$\varnothing d2$	72	83	100.6	108.6	138.6	163	189.1	245.1	293.5	338.5	385	435	486	534	630
	$\varnothing D2$	3.5	3.5	3.7	3.7	3.7	3.5	3.7	3.7	3.5	6	8	8	8	8	8
	$\varnothing d1$	25.3	35.3	46.6	59.6	74.6	96	116.5	161.5	200.5	238.5	283.2	328.2	375.2	426.2	510.2
	$\varnothing D1$	2.35	2.35	2.7	2.7	3.7	3.5	3.5	3.5	3.5	6	8	8	8	8	8
351 / 364	Weight (Kg)	0.69	0.86	1.2	1.49	2.42	3.29	4.72	7.92	13.73	21.04	31.5	47	70	96	135
365	Weight (Kg)	0.68	0.9	1.27	1.53	2.47	3.42	4.8	8.7	14.03	25.1	31.5	47	70	96	135

WAFER SWING CHECK VALVE

SIZE BETWEEN ISO PN10 FLANGES TYPES (en mm) :

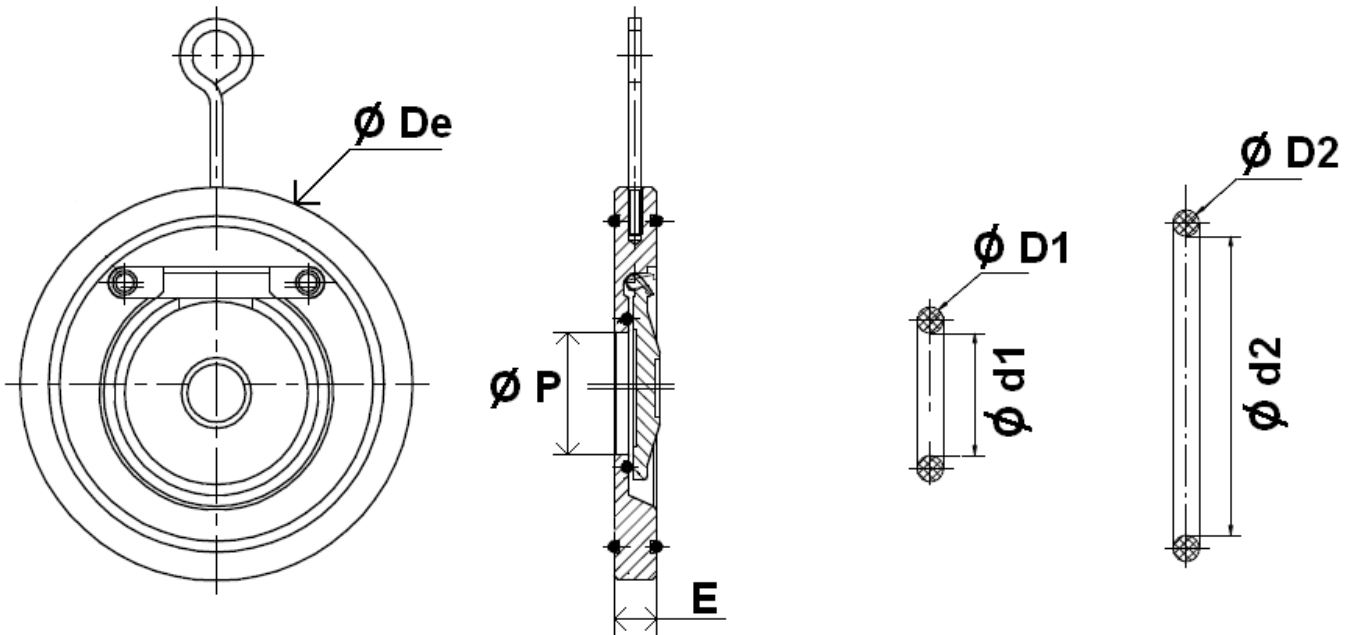

DN	400	450
E	41	50
$\varnothing De$	491	541
$\varnothing P$	315	359
$\varnothing d2$	435	486
$\varnothing D2$	8	8
$\varnothing d1$	328.2	375.2
$\varnothing D1$	8	8
Weight (in Kg)	47	70
Ref.	365401	365451

WAFER SWING CHECK VALVE

STANDARDS :

- Fabrication according to ISO 9001: 2008
- Designing according to API 594
- DIRECTIVE 97/23/CE : Products excluded (article 1, § 3-2)
- Length according to EN 558 series 97 (NF 29377) from DN 40 to 300 and from DN450 to 500
- Between flanges according to EN 1092-1 PN10/16

INSTALLATION POSITIONS :

Vertical position (ascendant fluid)

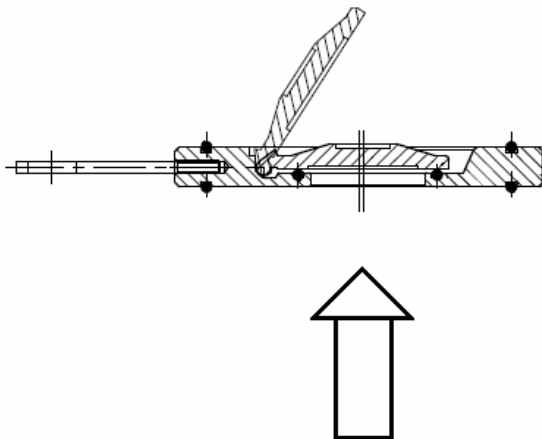

Horizontal position

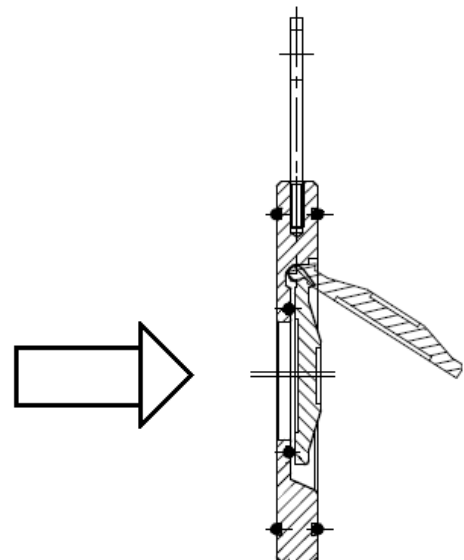

WAFER SWING CHECK VALVE

INSTALLATION INSTRUCTIONS

GENERAL GUIDELINES :

- Ensure that the check valves to be used are appropriate for the conditions of the installation (type of fluid, pressure and temperature).
- Be sure to have enough valves to be able to isolate the sections of piping as well as the appropriate equipment for maintenance and repair.
- Ensure that the valves to be installed are of correct strength to be able to support the capacity of their usage.

INSTALLATION INSTRUCTIONS :

- **Before installing the check valves, clean and remove any objects from the pipes** (in particular bits of sealing and metal) which could obstruct and block the valves.
- **Ensure that both connecting pipes either side of the check valve (upstream and downstream) are aligned (if they're not, the valves may not work correctly).**
- **Make sure that the two sections of the pipe (upstream and downstream) match, the check valve unit will not absorb any gaps. Any distortions in the pipes may affect the tightness of the connection, the working of the check valve and can even cause a rupture.** To be sure, place the kit in position to ensure the assembling will work.
- Make sure there is enough space so that the disc can be opened totally in the pipe.
- If there is a direction changing or if there's another material, it's better to take away the check valve so that it is outside the turbulence area (**between 3 and 5 times the ND before and after**).
- After a pump please refer to norm NF CR 13932 to install the check valve.